

SPECIFICATIONS

MEASUREMENTS

| | |
|-------------------------------|-----------------------------------------------------|
| Lamps | Metal halide 4 x 1,000 W |
| Generator | Brushless 60 Hz, 6.0 kW |
| Engine | Kubota® diesel 13.6 hp |
| Receptacles | One GFI duplex 20 A / 120 V One T/L 30 A / 240 V |
| Fuel capacity | 30 gal (114 L) |
| Wheel size | 13" (33 cm) |
| Axle rating | 2,000 lbs (907 kg) |
| Tongue weight travel position | 199 lbs (91 kg) |
| Total weight no fuel | 1,725 lbs (783 kg) |

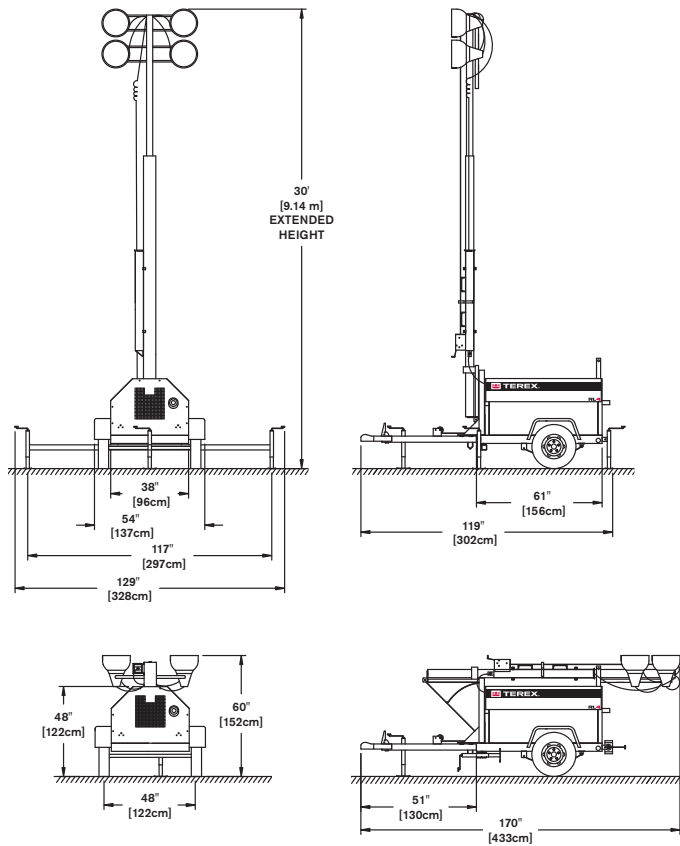

Notice: Metal halide lamp bulbs contain mercury (Hg). Dispose of lamp bulbs according to local, state and federal laws.

FEATURES

16" lamps 4 X 1000 W metal halide lights with Kubota engine and 6kW generator which provides quiet 71 dBA at 23 feet and fuel efficient 60 hour run time.

Durable 30' fully galvanized mast with dual self-braking winch design, 359 degree rotation, and retractable mast cable gives excellent illumination at long distances.

Standard engine protection includes high water temperature and low oil auto shutdowns.

Quick disconnect lights and ballasts allow for easy troubleshooting, service, and repair.

Standard DOT approved run, stop and turn lights

Compact design allows up to 10 units per truck while single point lifting eye and forklift pockets provide for easy loading and unloading

Highway safety chains with snap hook

RL™4 LIGHT TOWER



CHASSIS OPTIONS

Genie® branding and blue paint

Dome light with switch, 12V

Export racking and preparation

Hitch, 2 1/2 in. ring

Hitch, 2 5/16 in. ball

Hitch, combination ring and ball

Spare tire and wheel

ENGINE OPTIONS

6 kW, 60 Hz generator with 15.3 hp Perkins® diesel

7 kW, 50 Hz generator with 13.6 hp Kubota® diesel

Automatic air shutdown

Fuel/water separator filter

Fuel/water separator with fuel line heater

TOWER OPTIONS

4 horizontally mounted lights, cast aluminum square housing

19" lamps 4 X 1000W metal halide lights

COLD WEATHER OPTIONS

Cold weather package including: 700 CCA battery, battery heater blanket, engine block heater and low temperature coolant (-40F)



WORKS FOR YOU.™

www.genielift.com

Effective Date: January, 2014. Product specifications and prices are subject to change without notice or obligation. The photographs and/or drawings in this document are for illustrative purposes only. Refer to the appropriate Operator's Manual for instructions on the proper use of this equipment. Failure to follow the appropriate Operator's Manual when using our equipment or to otherwise act irresponsibly may result in serious injury or death. The only warranty applicable to our equipment is the standard written warranty applicable to the particular product and sale and we make no other warranty, express or implied. Products and services listed may be trademarks, service marks or trade names of Terex Corporation and/or their subsidiaries in the USA and many other countries. Terex, Genie and Works For You are trademarks owned or licensed by Terex Corporation or its subsidiaries. All other trademarks are property of their respective owners. © 2014 Terex Aerial Work Platforms. RL4 0210F Part #109044

Genie United States
18340 NE 76th Street
P.O. Box 97030
Redmond, Washington 98073-9730
Telephone +1 (425) 881-1800
Toll Free in USA/Canada +1 (800)-536-1800
Fax +1 (425) 883-3475

Genie Europe
The Maltings
Wharf Road
Grantham NG31 6BH
UK
Telephone +44 (0)1476 584333
Fax +44 (0)1476 584334
Email: AWP-InfoEurope@terex.com

Distributed By:



WORKS FOR YOU.™